

POLYGYR®

Universal controller

for comfort heating /
ventilating / air conditioning plants

Version: from SW 101, from index C

RWX62...

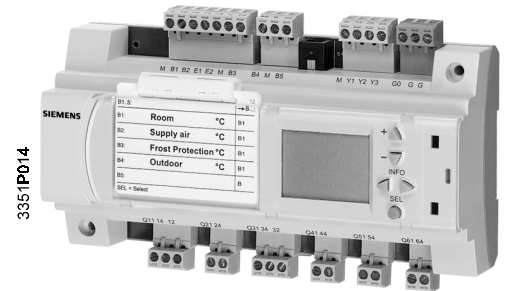

Fully autonomous electronic universal controller with up to three configurable controllers as sequence controllers with P, PI, PID response or as digital controllers with P-response. Universal inputs for analog or binary signals. Separate outputs for analog or binary signals. AC 24 V operating voltage. Direct entry and setting of all data on the controller; no extra tools required.

Use

The universal controller is primarily intended for comfort ventilating and air conditioning plants. However, the controller can also be used in comfort heating plants.

Controlled variables

The following variables can be controlled:

- Temperature -35...130 °C
- Relative humidity 0...100 %
- Absolute humidity 0...20 g/kg
- Enthalpy 0...100 kJ/kg
- Pressure 0...40 bar
- Pressure differential in liquid media 0...10 bar
- Pressure differential in gaseous media 0...500 Pa or 0...3.00 kPa
- Volumetric air flow 0...850 m³ /s or m³ /h or l/h
- Indoor air quality 0...2000 ppm CO₂ (0...200 display)

Application functions

- Controller:
 - 1...3 sequence controllers with auxiliary functions and analog and digital (two-position) outputs or
 - 1...3 digital controllers with digital (two-position) outputs
- Auxiliary functions:
 - Operating mode changeover
 - Setpoint compensation
 - Switching function in dependence of outside temperature
 - Cascade control
 - Minimum and maximum limitation
 - Frost protection function
 - Message on excessive control deviation
 - Maximum priority for cooling/dehumidifying
 - Reversal of operating action of the positioning signal

Type summary

Inputs		Outputs		Type reference
Analog/Binary	Binary	Analog	Binary	
3	2	3	0	RWX62.5030
5	2	3	2	RWX62.7032
5	2	3	4	RWX62.7034
5	2	3	6	RWX62.7036

Spare parts

Basic documentation POLYGYR, English	CM2Z3351E
Installation and commissioning guide English	
including operating cards (other languages are available)	ARG62.120EN
Operating card holder	PUP1.2
Flush panel mounting frame	ARG62.10

Customized units

Landis & Staefa Division supplies customized units on large orders; these units differ as follows from standard units with regard to configuration and/or design:

- Pre-configured applications within the standard options range
- Preset, adjustable parameters within the standard options range
- Unit with e.g. customer logo and customized type reference

Please contact the Landis & Staefa branch or representative in your area for customized units.

Equipment combinations

The following Landis & Staefa sensors, actuators and signal converters can be connected to the POLYGYR universal controllers RWX62...:

Unit	Data sheet no.
• Sensor with LGNi 1000 Ω temperature sensing element	17... to 19...
• Sensor with DC 0...10 V measuring signal	17... to 19...
• Frost sensor QAF63... and frost monitor QAF64...	1821 / 1283
• Room temperature sensor with setpoint adjuster QAA25	1721
• Remote setpoint adjusters FZA21.11 + FZA61.11	198...
• Air damper actuators with DC 0...10 V input	46...
• Valve actuators with DC 0...10 V input	45...
• Control valves	46...
• Signal converter SEM 61.4 for current valve control	51...
• Various signal converters	34...

Combinations using third-party units are possible, provided they correspond to the input and output specifications of the POLYGYR RWX62....

POLYCOPY

POLYCOPY is a set consisting of one POLYCOPY adapter, AC 24 V transformer, connecting cable and the POLYCOPY software which is used for copying and saving configurations of the RWX62... universal controllers.

Functions

The RWX62... universal controller executes main and auxiliary functions. You can specify the desired effect by entering configurations and setting parameters. Each input is based on a function code. In the data sheet, the [function code] is printed in brackets.

Controller types

The universal controller can alternately be used as either a sequence or digital controller.

Sequence controller

[SEQREG] with up to three mutually independent P, PI or PID controllers.

Digital controller

[DIGREG] with up to three mutually independent P-controllers.

Main functions
Sequence controllers

A sequence controller may comprise a maximum of four sequences (seq.1...4) combined as follows:
 One sequence: seq.1 or seq.3
 Two sequences: seq.1+2 or seq.1+3 or seq.3+4
 Three sequences: seq.1+2+3 or seq.1+3+4
 Four sequences: seq.1+2+3+4

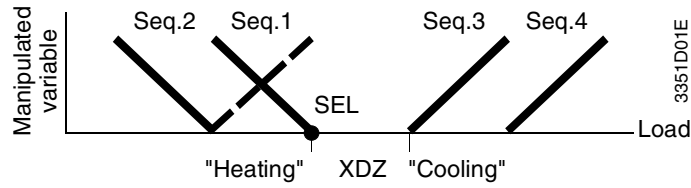

Operating action The "Heating" setpoint [SEL] is allocated to the interdependent sequences 1 and 2. Their output signal acts in reverse to the load (input variable), e.g. heating.
Note Seq.1 can be set to act directly on the load, e.g. cooling.

The "Cooling" setpoint is allocated to the interdependent sequences 3 and 4. Their output signal acts directly to the load (input variable), e.g. cooling.

Zero energy band The zero energy band (XDZ dead zone) lies between the "Heating" and "Cooling" setpoint, i.e., between sequences 1 and 3.
 The "Heating" setpoint and the dead zone can be changed by the user within adjustable limits for standard operation.

Controller outputs One analog output (Y1...3) and/or 1...6 binary outputs (Q1...6) can be allocated to each sequence; these outputs then act in the operating action of the sequence as follows:

Analog outputs

- Modulating output (Y...) to control positioning units with a DC 0...10 V positioning signal input
- Modulating output (Y...) combined with binary outputs (Q...) to switch plant elements in dependence of the Y-signal (e.g. pump switching in dependence of the valve position)

Binary outputs

- One binary output Q..) for single-step switching
- Linear step switch with 2...6 steps, i.e. 2...6Q
- Binary step switch with 2...4 Q (2Q= 3-step, 3Q= 7-step, 4Q= 15-step)
- Step switch (Q...) combined with Y... for modulating output control between the individual steps

Example Ventilating plant with room temperature control
 B1 = Room temperature
 Seq.1 = Heat recovery, acting directly or reversed depending on the system
 Seq.2 = Heating, reverse action
 Seq.3 = Cooling, direct action
 Seq.4 = Unused

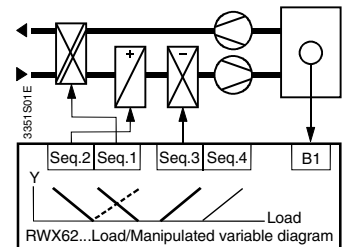

Auxiliary functions sequence controller

The section below shows all possible optionally selectable sequence controller auxiliary functions based on typical ventilating/air conditioning applications. The individual auxiliary functions can be configured by selecting the associated [function code or symbol].

Operating mode
changeover

[NIGHT] and/or [STNDBY]

E1 = "Night" operation (NIGHT) input signal
E2 = "Standby" operation (STNDBY) input signal

"Night" operation: [☾ NIGHT]

On switching an AC 24 V signal (e.g. via a timer) to a binary input **E1**, the control loop is switched to the "Night" setpoint(s).

(see parameterization tables).

"Standby" operation: [⏻ STNDBY]. On switching an AC 24 V signal (e.g., fan OFF message) to binary input **E2**, the control loop is switched to a zero output state excepting the frost protection function.

For each controller, an E1 and E2 binary input is available for all active sequence control loops. Their influence on each operating mode and each control loop can be enabled or disabled.

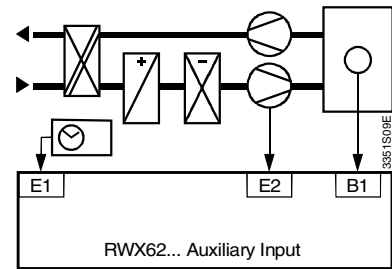

Setpoint actual value
deviation alarm

[DEVALM]

Q... = Deviation alarm

On long-term actual value deviations (adjustable time) outside of the set tolerance limit, a de-energized open **alarm contact** Q... is closed (e.g., to actuate a separate alarm siren). At the same time, the deviation alarm is indicated on the LCD. After returning to the accepted actual value deviations, the deviation alarm is deactivated automatically.

For each controller, one common deviation alarm contact is available for all active sequence control loops. The alarm function can be deactivated by entering an extreme setting for the corresponding DEVALM setpoints.

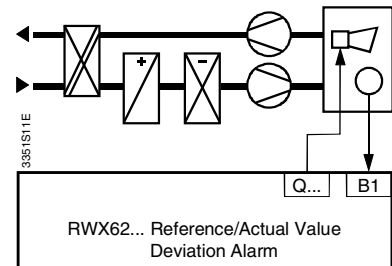

Remote setpoint
presetting

[TELSEL]

B... = Remote setpoint

The **standard or "Day" operation setpoint** can be set via a separate remote setpoint potentiometer B... (separate potentiometer or potentiometer integrated in the room temperature sensor). The remote setpoint setting range can be limited in the controller. A dead zone [XDZ] can also be set between the setpoints "Heating" and "Cooling". Possible "Night" setpoint(s) are not influenced by the remote setpoint. The remote setpoint function is not available for control loops with a compensated setpoint.

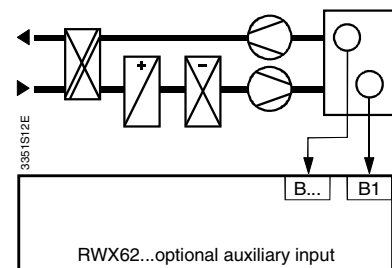

Setpoint compensation

[MULFUN] and [COMP] setpoint compensation
[CONST] constant setpoint

B2 = Compensation variable [MULFUN]
B1 = Compensated variable [SEQREG]

With the so-called **"multifunction"** measured variable, the controller setpoint for instance can be compensated to the outside temperature. For each controller, one common multifunction measured value is available for all active sequence control

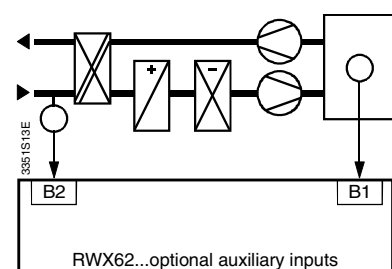

loops. Their influence on the controller setpoint can be enabled or disabled for each operating mode or control loop.

You can set summer and/or winter compensation. The setpoint is compensated via the value of input MULFUN as follows:

Summer **and** winter compensation \Rightarrow SEL3 \neq SEL2

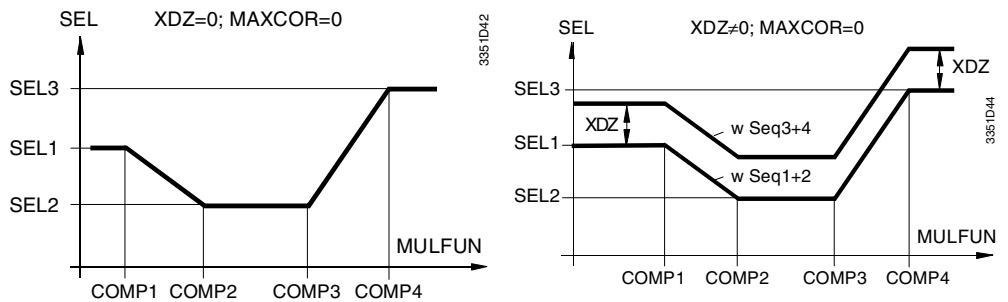

You can select different setpoints for seq.1+2 and seq.3+4.

Summer **or** winter compensation \Rightarrow SEL3 = SEL2

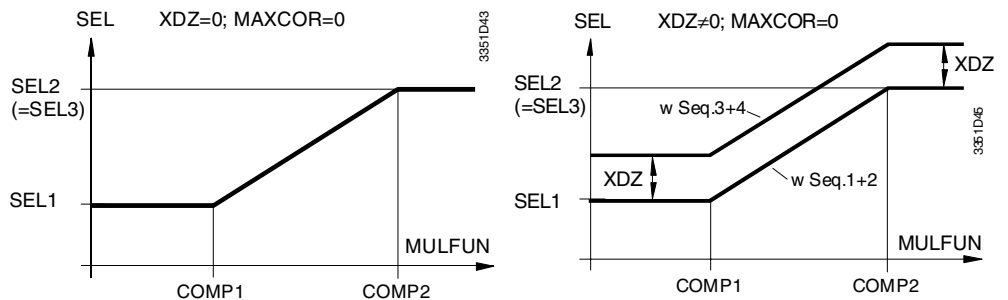

If you enter SEL3 = SEL2, prompts for COMP3 and COMP4 values no longer appear.

Shifting the "Day" setpoint of AUTO MODE.

You can shift the specified setpoint curve in AUTO MODE by means of parameter COR within the range $-MAXCOR \dots +MAXCOR$.

For a compensated "Day" setpoint, the following alternative controller setpoints are available for night operation:

- Constant "Heating" and "Cooling" setpoints with zero energy band (dead zone) or
- Controlled "Heating" and "Cooling" setpoints with zero energy band (dead zone)

For a compensated "Night" setpoint, the unchanged "Day" setpoint is altered by the set corrective value \odot COR. In this instance, the "Heating" setpoint of seq. 1+2 is lowered and the "Cooling" setpoint of seq. 3+4 is increased. This then results in a dead zone that corresponds to twice the corrective value. \odot COR can be set from 0 to MAXCOR.

General minimum and maximum limitation (PI)

[LIM]

B... = Supply air sensor

The **general limiter function** with PI response allows for the following:

- Absolute maximum and minimum limitation (e.g., supply air or humidity)

When the value drops below or exceeds the limiter setpoint, the PI limiter function overrides the standard control function to maintain the limiter setpoint.

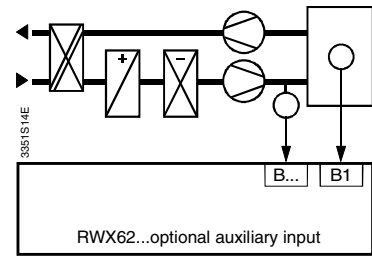

[RELLIM].

- Maximum temperature differential limitation: (room temperature B1 - supply air temperature B...)

When the value drops below the limiter setpoint, the PI limiter function overrides the standard control function to maintain the limiter setpoint. The supply air temperature cannot drop below the current room temperature actual value by more than the set temperature differential.

Cascade control PI/PI

[LIM + CASC ACTIV]

B... Supply air temperature sensor

You can select the **PI/PI room/supply air temperature cascade control function** in addition to the limiter function. In this case, the virtual PI room temperature controller determines the setpoint within the limiter setpoints for the PI supply air temperature controller.

Minimum limitation PI for sequence 1

[LIMSPE]

B... = Temperature sensor to detect risk of icing on the air side (e.g., in the extract air heat exchanger of a system connected to the control loop used to acquire the water / glycol inlet temperature). The minimum limitation for seq.1 allows for implementing **icing protection** for PI extract air heat recovery.

When the value drops below the limiter setpoint, the PI limiter function overrides the standard control function seq. 1 to maintain the limiter setpoint.

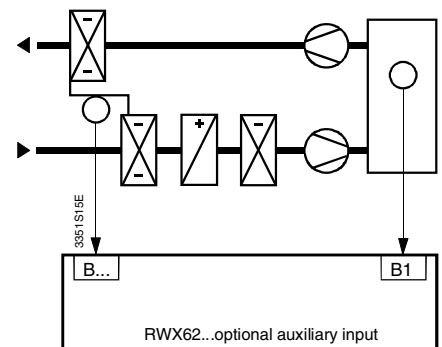

Other typical applications (e.g.): Maintenance of the water inlet temperature in a corrosion-prone heating boiler.

Maximum limitation PI for sequence 3

[LIMMAX]

B... = Room humidity sensor

Maximum PI room humidity limiter for cooling output control (= dehumidification) of sequence 3.

When the value exceeds the limiter setpoint, the PI limiter function overrides the standard control function seq. 3 to maintain the limiter setpoint.

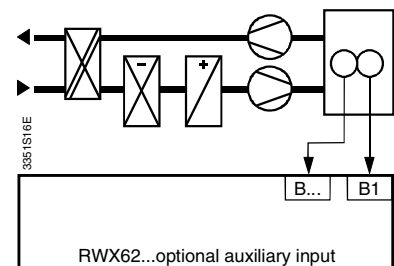

The resulting undercooling of the supply air/room temperature is corrected by the room temperature sequence controller via increased (re)heating.

Max. priority control for sequence 3

[MAXPRI]

B... = Dehumidifying signal DC 0...10 V from a separate room humidity control loop (poss. with additional humidifying control outputs).

Priority cooling/dehumidifying in seq.3:

The dehumidification signal is sent to input B... [MAXPRI]. For output seq.3, a maximum selection of the dehumidifying signal and of the cooling output demanded by the sequence controller is formed. The resulting undercooling of the supply air/room temperature is corrected by the room temperature sequence controller via increased (re)heating.

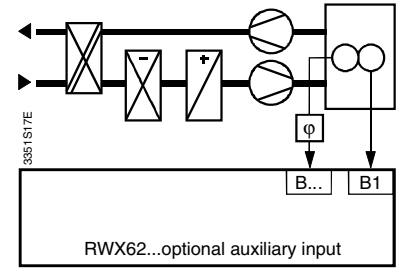

Frost monitor

[*PROT]

B... = AC 24 V of the frost protection thermostat

Two-position frost protection

for water / heating coil:

On interruption of the signal on input B...:

- Seq.1+2 with Y outputs move to 100 % heating output
- All other sequences move to zero output
- Signal level limitations are ineffective
- The LCD indicates a frost alarm

After the AC 24 V signal returns to input B... (i.e., danger of frost no longer exists), the sequence controller resumes standard control operation.

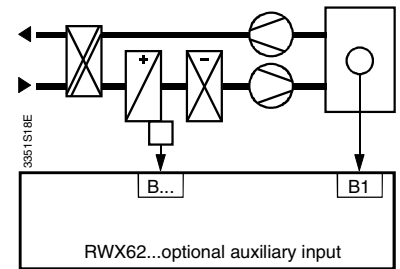

During "Standby", all frost protection functions remain active. When control operation is disabled, all frost protection functions are also disabled. When frost protection is active, but the heating output is insufficient (e.g., no heating water), the frost protection function cannot protect the plant from frost damage.

Super frost protection PI limiter

[S*PROT]

B... = Correctly placed temperature sensor on the water / heating coil.

Q1= Frost alarm changeover contact

Normally open contact Q14: Fans, etc. locking.

Normally closed contact Q12: External alarm (e.g., siren).

K1 External plant switching command 0/1

2-phase, **modulating/2-position frost protection limitation function** for water / heating coils **with frost protection alarm contact (Q1)**.

The super frost protection function works in two phases:

1. Modulating super frost protection PI limiter phase:

When the value drops below the current limiter setpoint, the modulating PI limiter function overrides the current sequence controller function to maintain the limit value. In this case, the Y-signal level limitations temporarily are rendered ineffective (fresh air dampers are completely closed for 100 % heat recovery).

- In control operation:
 - The limiter setpoint is permanently set to 7 K above the alarm setpoint
 - Limitation acts on all active sequences 1...4

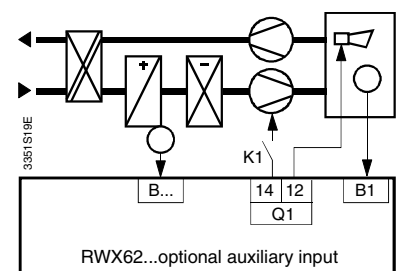

- In Standby mode:
 - The limiter setpoint is adjustable, but must be at least 7 K above the alarm setpoint
 - The limitation acts only on the reverse acting sequences 1+2 with Y; defined Y-signal limitations are ineffective

2. Two-position super frost alarm phase:

This phase is active only when the frost protection temperature drops below the specified super frost alarm setpoint despite the previous modulating super frost PI limiter phase. This triggers the following responses:

- Ventilation is deactivated via alarm contact Q1 and the external alarm is activated
- Sequences 1+2 with Y outputs move to 100 % heating output
Signal level limitations are ineffective
- All other sequences move to zero output
- The LCD indicates a frost alarm

After the temperature again exceeds the alarm setpoint, the sequence controller resumes operation as soon as the frost alarm has been acknowledged.

The following alternative alarm acknowledgement methods are available:

- Automatic acknowledgement on temperature increase [AUTO]
- Manual acknowledgement (press button on controller) of each alarm [MANUAL]
- Manual acknowledgement (press button on controller) of every third consecutive alarm sent within 30 minutes [MANU3]



During Standby operation, the super frost protection functions remain active. When control operation is disabled, all super frost protection functions are also disabled. The super frost alarm contact then moves to the alarm position. On failure of the super frost temperature input, the super frost protection function moves to the alarm state. When the super frost protection function is active, but heating output is insufficient (e.g., no heating water), the super frost protection function cannot protect the plant from frost damage.

Control in dependence
of outside temperature

[MULFUN] and [RELEAS ACTIV]

Multifunction-dependent switching of Q...with Y...:

B2 = Multi-function measured value (here: outside temperature)

Additional outside temperature-dependent activation of the hot water circulation pump Q...:

This, for example, allows for keeping the hot water circulation pump active (also during Standby mode) in combination with super frost protection monitoring for as long as the outside temperature is below the associated setpoint (e.g. <2 °C; adjustable).

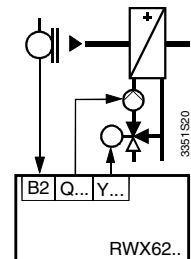

Operating action
reversal sequence 1

[MULFUN] and/or [ALTDIR]

The operating action for sequence 1 can be reversed. Reversal depends on whether the sequence was configured to [REVERS] (\\ _ / /) or [DIRECT] (\ / _ / /) during standard operation.

The following changeover actions are possible:

1. Changeover from external via digital signal AC 24 V [DIG]

This signal must be configured to input [ALTDIR] with [DIG] .

2. Changeover in the case of an adjustable value [ABS]

The following measured values are used:

If only MULFUN is configured: Input [MULFUN]

If MULFUN and ALTDIR are configured: Input [ALTDIR]

If only ALTDIR is configured: Input [ALTDIR]

3. Changeover in the case of an adjustable difference between two measured values ($\Delta B...-B...$)



This changeover is possible only if both B are configured as temperature sensors (1xNi; 2xNi or VOLT °C).

The following measured value differences are possible:

If only MULFUN is configured: $[\Delta B... \text{ MULFUN} - B... \text{ SEQREG}]$

If MULFUN and ALTDIR are configured: $[\Delta B... \text{ MULFUN} - B... \text{ [ALTDIR]}]$

Locking sequences in
dependence of outside
temperature

[MULFUN] and [LOCK]

The [LOCK] function allows for locking individual sequences in dependence of the input variable on [MULFUN] (e.g. outside air temperature).

The cooling sequences can be locked on low and the heating sequences on high outside air temperatures. This ensures that, among other things, heating is not active in summer and cooling is not active in winter for compensated setpoints that are based on outside air temperature.

The [LOCK] function can be activated for sequences 1+2 and / or sequences 3+4. This function is active also during Night operation.

Priorities of sequence controller functions

The previously described sequence controller functions have the following priorities in the sequence control loop (1= highest priority)

Control operation

- 1: "OFF" via E2 [STNDBY]
- 2: "Night" operation via E1 [NIGHT]
- 3: "Day" or standard [MODE]

Limiter and priority
functions

1. Delay times [T1 and T2]
2. Frost protection [* PROT] or [S * PROT]
3. Activation of Qs via MULFUN [RELEAS]
4. Maximum selection seq.3 [MAXPRI]
5. Auxiliary controllers seq.1 and seq.3 [LIMSPE] and [LIMMAX]
6. General limiter [LIM]
7. Locking sequences via MULFUN [LOCK]
8. Sequence controller [SEQREG]

Main functions digital controller

For single- or multi-step P-control of the control variable acting on one or several two-position output elements.

[DIGREG]

The digital controller has 1...6 binary outputs (Q1...6) with adjustable setpoint per switch-on and switch-off point for each binary output (see parameterization tables).

Example: Digital controller with four binary outputs.

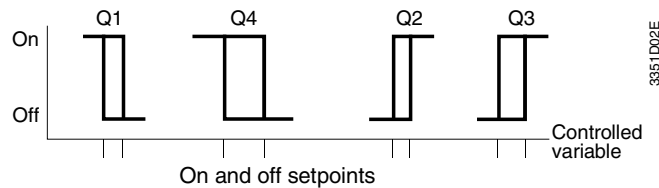

Auxiliary functions digital controller

[STNDBY]

By switching an AC 24 V signal (e.g., via a timer) to input E2, the digital controller is switched to the zero energy (Standby) state. At the same time, all Q-outputs are deactivated.

For each controller, one common E2 binary input is available for all active digital control loops. Its influence on each operating mode and each control loop can be enabled or disabled.

Technical design

Operational safety

The automatic control operation is secured against measured value range violations or universal input (B) errors by means of the following responses:

1 x NI °C and 2 x NI° C

Measured value < -50 °C or > 150 °C means short-circuit or interruption.

This results in the following:

- ERROR replaces the associated actual value on the LCD
- For sequence or digital controller input: controller outputs switch to 0 % output. Frost protection functions remain active
- For super frost protection input: changeover to super frost alarm
- Other inputs: the associated function is ineffective

Remote setpoint

Measured value > 1200 Ω stands for an interruption and has the following effect:

- ERROR appears on the LCD
- Sequence controller without night operation: outputs switch to 0 % output
Frost protection functions remain active
- Sequence controller with night operation: changeover to night operation with night setpoint(s)

DC 0...10 V

Measured value < -1.4 V or > 11.4 V has the following effect:

- Flashing actual value display of the associated range end value
- Indication of the associated control or auxiliary function by including the range end value

Mechanical design

Housing

The RWX62... universal controller is a compact unit accommodated in a closed plastic housing as per DIN 43 880 Gr 1 with the following features:

Mounting options

The following mounting options exist for control cabinet mounting:

- Mounting in a standard cabinet as per DIN 43 880
- Wall mounting on an existing top-hat rail (EN 50 022-35x7.5)
- Wall mounting using two fixing screws
- Flush panel mounting with ARG62.10 mounting frame

Connection terminals

Plug-in screw terminals. The terminals for G, G0 are orange to enable easy, unambiguous distinction.

Operating and display elements

Operate the RWX62... by actuating the operating elements on its front panel. No auxiliary tools such as PC tool, etc. are required.

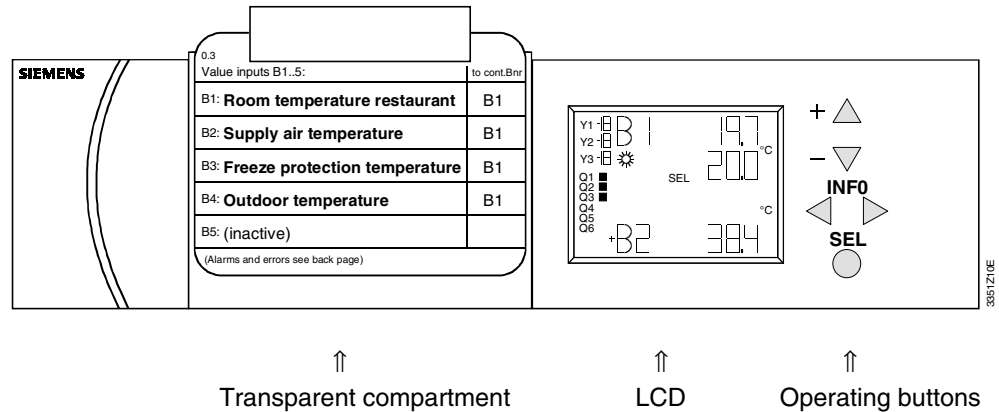

Transparent compartment

The transparent compartment contains the application-specific operating instructions (operating cards).

LCD

The following information is indicated on the LCD:

- The current operating values (maximum 3 digits)
- The functional code and the symbols

Operating buttons

The operating buttons have the following functions:

INFO

Use the INFO operating buttons to select the information picture (function code).

Use the left arrow button (<) to select the previous picture and the right (>) for the next one.

Use the right arrow (>) to acknowledge a flashing display and simultaneously proceed to the next picture.

SEL

Use the SEL button to enable changes or acceptance of the settings. Flashing displays mean: the data can be changed.

+ / -

Use the + / - buttons to increase or decrease the flashing data values.

Operation

You can choose different operating modes:

Controller operating mode

Operation of the configured control loops with general access.

- Display of all current input and output states on the LCD
- Option to modify the standard ("Day") operating setpoint for each configured sequence controller. Settings are possible within the limits defined in the parameterization mode (MINSEL...MAXSEL or + / - MAXCOR)
- Manual acknowledgement of possible super frost alarms

Configuration mode Parameterization mode Simulation mode

These modes are accessible only to experts to protect the settings; see engineering notes.

Engineering notes

Intended use	Use this unit only for applications as described in the brief description on the title page (bold print) and the section "Use". Additionally, observe all conditions and restrictions imposed in this section and in "Technical data".
	The sections marked with a warning symbol as shown to the left contain technical safety requirements and restrictions. Observe all of these warnings as they directly relate to the protection of personnel and equipment.
Technical design	<p>To engineer HVAC control loops, HVAC experts must first define the following for the desired application:</p> <ul style="list-style-type: none">• Controller type (sequence controller or digital controller)• Controlled variable (e.g., room temperature or room humidity, etc.)• Type of setpoint (e.g., constant setpoint or compensated setpoint, day/night setpoint changeover, etc.)• Type and sequential positioning of the control elements (e.g., modulating heating valve or multi-step electric heating, etc.)• Additional functions (e.g., remote setpoint and or limitation and/or reference variable, etc.)
Notes	Refer to POLYGYR CM2Z3351E for a detailed description. This manual also contains a commissioning protocol with configuration and parameterization tables.
Configuration mode 2	[CO2] Configuration starting point. This is where you allocate the inputs and outputs to the control loops. After quitting configuration mode 2, the function configurations and the input and output terminal designations are all defined. The optimal unit type is also defined.
Configuration mode 1	[CO1] Fine tuning of the configuration data, such as °C/K or °F display, P/PI or PID mode, cascade function inactive, active, etc.
Parameterization mode 2	[PA2] Setting of all fine-tuning parameters such as P-bands, integral action time, measured value corrections, actual value limitations, delay times, etc.
Parameterization mode 1	[PA1] Setting of all setpoints for both sequence controllers and associated auxiliary controllers.
Simulation mode	[SI] In the simulation mode, you can check the configured functions by entering simulated power values (sequence controller) or simulated actual values (digital controller). The sequence diagram (sequence controller only) and the output values appear on the LCD. This allows you to check both switching points and plant wiring.

Installation notes

For DIN rail (top-hat rail) mounting, no additional components are required (A).

Two screws of the following size are necessary for screw mounting: dia 3.7 mm (B).

For flush panel mounting, the ARG62.10 mounting frame is necessary. (C)

The plug-in terminals can be connected to the litz wire before or after flush panel mounting. (Use litz wire for reasons of moveability.)

Mounting by means of DIN rail (A)

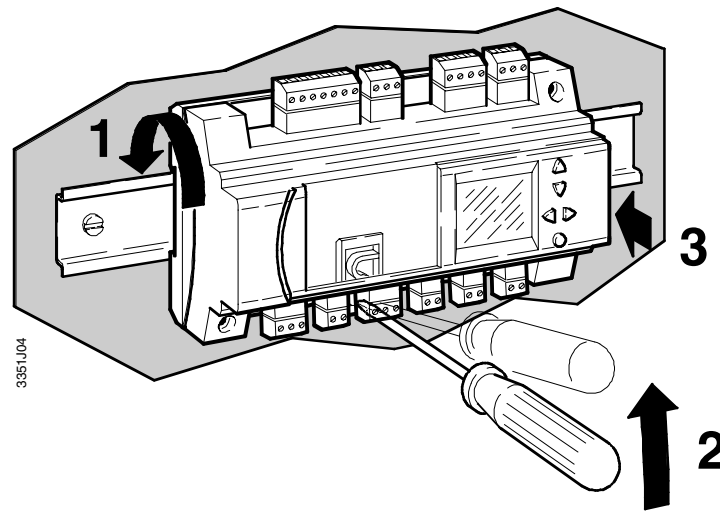

Wall mounting (B)

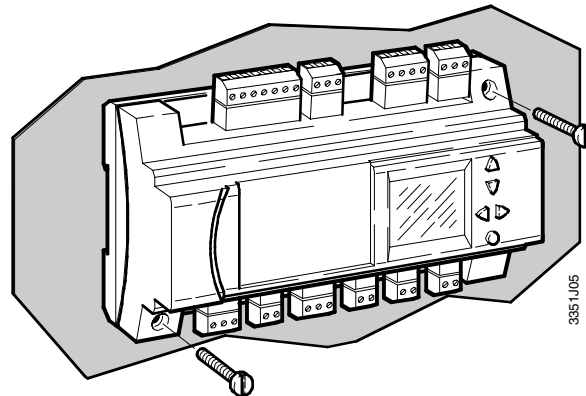

Flush panel mounting (C)

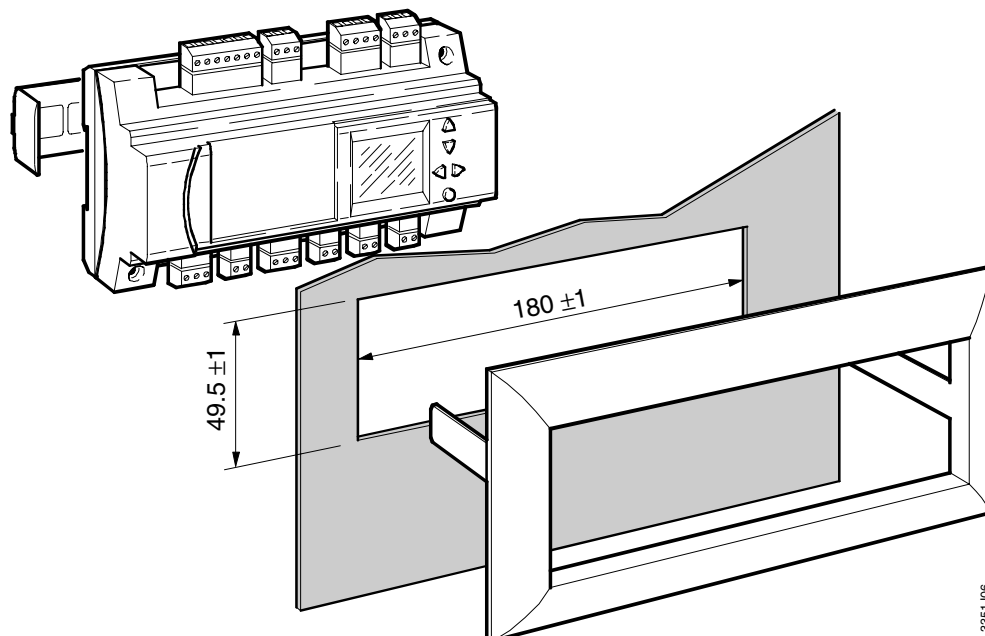

Electrical installation



You can use normal cables for wiring the POLYGYR system. However, when mounting in an extremely impaired EMC environment, use only shielded cables.

The operating voltage must comply with the requirements for safety extra-low voltage (SELV) as per EN 60 730.

Use safety insulating transformers with double insulation as per EN 60 742; they must be designed for 100 % on-time.

When using several transformers in one system, the connection terminals G0 must be galvanically connected. The POLYGYR RWX62...units are designed for operation of AC 24 V max.10 A safety extra-low voltage and are short-circuit-proof.

Supplying voltages above AC 24 V to low voltage connections may damage or destroy the controller or any other connected devices. Additionally, connections to voltages exceeding 42 V endanger personnel safety.

Connect only mains voltages of up to max. AC 250 V to the potential-free contacts Q.

Commissioning notes

Required reference documentation

The following documentation comprises all information necessary for commissioning:

- The installation and commissioning instructions supplied with the universal controller
- Commissioning protocol with project-specific entries
- Plant wiring diagram as well as further control documentation stored in the control cabinet or with the plant manager

Configuring and parameterizing



Only HVAC experts may configure (program) and parameterize (setting the values) controllers for plant-specific operation.

Observe the following:

- The unit must be connected and AC 24 V must be supplied
- The values and settings specified in the unit remain in memory even on power failure
- Data entries made to the commissioning protocol during engineering must be transferred to the unit. Refer to the POLYGYR User's Guide for detailed procedures. The User's Guide provides blank tables in the appendix
- Manually record the application-specific data on the operating cards supplied with the unit and store them in the controller's transparent compartment

Technical data

General data

 Power supply	Operating voltage	AC 24 V \pm 20 % Q1...Q6 AC 24...230 V)
	Safety extra-low voltage SELV as per	EN 60 730
	Frequency	50 Hz / 60 Hz
Power consumption	RWX62.5030	4 VA
	RWX62.7032	5 VA
	RWX62.7034	6 VA
	RWX62.7036	7 VA
Prompting speed	Output renewal speed	1 s
Displays (LCD)	Actual values and setpoints	3-digit
	Resolution of values <100	0.1
	Resolution of values >100	1
	Resolution of ranges <10	0.01
	Analog outputs (-1...11 V)	2-digit, resolution 1 Volt / 10 %
Environmental conditions	Binary switching outputs	OFF/ON
	Transport	IEC 721-3-2
	Climatic conditions	Class 2K3
	Temperature range	-25...+70 °C
	Humidity	< 95 % r.h.
	Mechanical conditions	Class 2M2
	Operation	IEC 721-3-3
	Climatic conditions	Class 3K5
	Temperature range	0...50 °C
	Humidity	< 95 % r.h.
Degree of pollution	Normal pollution	EN 60 730
IP-Code	Housing	IP 20 as per EN 60 529
	Front	IP 40 as per EN 60 529
Product standards	Automatic electrical controls for household and similar use	EN 60 730
	Energy management equipment	UL 916
Quality assurance	Production and customer service	as per ISO 9001
 conformity	In accordance with European Union directives	
	Electromagnetic compatibility EMC	89/336 EEC
Standards	Low voltage guideline	73/23/EEC
	Emissions	EN 50 081-1
	Immunity	EN 50 82-1
	Immunity Industrial Sector *	EN 50 82-2
	Safety	EN 60 730

*The RWX62... can be used in areas as defined by "EN 50 082-2 industrial environment", provided the following requirements are met:

1. Integration in a completely enclosed steel plate housing.
2. All connections with shielded cables (multi-core cable with common shield permissible).
3. Connection of all line shields at the cable entry with the housing.
4. The cable shields must be connected only on the RWX62... side.

Connection terminals	Plug-in screw terminals for wires of	min. dia. 0.5 mm max. 2x1.5 mm ² or 1x 2.5 mm ²	
Tool connection	Connector plug for POLYCOPY	4-pin	
Weight without packaging	RWX62.5030	0.38 kg	
	RWX62.7032	0.40 kg	
	RWX62.7034	0.44 kg	
	RWX62.7036	0.46 kg	
Dimensions	Refer to "Dimensions" for more information		
Universal inputs B1...5			
Temperature sensors (LG Ni 1000 / 0 °C)	Range	-35...130 °C	
	Under- and overrange	-50...150 °C	
	Resolution	< 0.05 K at 0 °C	
	RWX62... accuracy	-0.5K ...+0.5 K	
	Measuring voltage	max. DC 5.0 V	
	Measured current	2.6...3.4 mA	
	Max. permissible cable length for dia. ≥0.6 mm	max. 300 m (4.5 Ω total line resistance corresponds to approx. 1 K error)	
	Temperature sensors LG Ni 1000 (2 x LG Ni1000 / 0 °C parallel)	Range	-35...130 °C
		Under- and overrange	-50...150 °C
		Resolution	< 0.1 K / 0 °C
RWX62... accuracy		-1K...+1 K	
Measuring voltage		max. DC 5.0 V	
Measured current		3.1...3.9 mA	
Max. permissible cable length for dia. ≥0.6 mm		max. 300 m (2.25 Ω total line resistance corresponds to approx. 1 K error)	
Analog voltages (for measured variables in °C, % or without unit)		Range	DC 0...10 V
		Under- and overrange	DC -1.4...11.4 V
		Resolution	1.0 mV
	RWX62... accuracy	-0.1...+0.1 V at 0 V -0.25...+0.25 V at 10 V	
	Max. current consumption	0.11 mA	
	Internal resistance R _i	≥ 100 kΩ	
	Max. permissible cable length for dia. ≥0.6 mm	max. 300 m; see also information for connected unit	
	Remote setpoints B2...5	Range	0...1000 Ω
		Overreach	1200 Ω
		Offset unit	0.15 Ω
RWX62... accuracy		-2.5 Ω...+2.5 Ω at 1000 Ω -5 Ω...5 Ω at 0 Ω	
Measured voltage		max. DC 5 V	
Measured current		2.9...4.4 mA	
Max. permissible cable length for dia. ≥0.6 mm		max. 300 m (10 Ω total line resistance corresponds to 1% error)	
Binary voltage inputs		Voltage	AC 24 V
		Current consumption	≤ 8 mA
		log. 0	AC ≤ 5 V eff.
	log. 1	AC ≥ 15 V eff.	

Binary control inputs E1, E2	Polling voltage for control commands	AC 24 V
	Current consumption	≤ 8 mA
	Max. permissible cable length for dia. ≥0.6 mm	max. 300 m
Analog outputs Y1...Y3	Range	DC 0...10 V
	Under- and overrange	DC -1.4...11.4 V
	Resolution	15 mV
	Working voltage	max. ±1 mA
Binary switching outputs Q1...Q6	Switching output of the relay contacts Q1..Q6	
	AC voltage	AC 24...230 V, 4 A res., 3 A ind.
	DC voltage	DC max. 50 V, max. 40 W, max. 5 A
	Min. contact rating for mains voltage	AC 230 V / 5 mA
	for low voltage	DC 24 V / 10 mA
	Max. switch-on current	10 A (1 s)
	Life of the relay contacts	
	Alternating voltage at 0.1 A res.	2×10^7 cycles
	at 0.5 A res.	2×10^6 cycles
	at 3 A res.	2×10^5 cycles
	Red. factor for ind. loading (cos. phi = 0.8)	0.85
	Direct voltage	2×10^5 cycles
	External fuse on input side	max. 10 A
	Changeover switch	Q1 and Q3
	ON/OFF-switch	Q2, Q4...Q6
Insulation resistance		
Between relay outputs and safety extra-low voltage (SELV)	AC 3750 V, as per EN 60 730 - 1	
Between relay outputs of neighbouring relays	AC 3750 V, as per EN 60 730 - 1	

Internal diagram

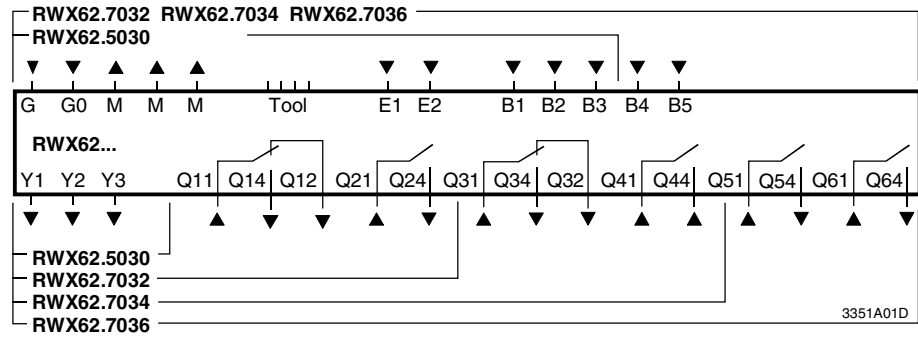

G-G0: AC 24 V supply

M: Ground (G0) for signals, universal inputs, analog outputs

B: Universal input

E: Binary input

Y: Analog output

Q: Binary output, various voltages permissible

Tool: Connection for POLYCOPY

Dimensions

