

## Electric actuators for valves with a 5.5 mm stroke

**SQS35...**  
**SQS65...**  
**SQS85...**

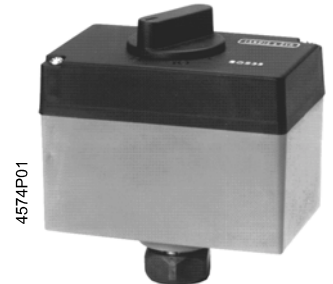

SQS35.50, SQS35.53  
SQS65.5  
with spring return / without manual adjustment



SQS35.00, SQS35.03, SQS65, SQS65.2  
SQS85.00, SQS85.03  
without spring return / with manual adjustment

### Electric actuators

- **SQS35... AC 230 V operating voltage, 3-position control signal**
- **SQS85... AC 24 V operating voltage, 3-position control signal**
- **SQS65... AC 24 V operating voltage, DC 0 ...10 V or DC 2 ... 10 V control signal**
- **Positioning force 400 N**
- **Stroke 5.5 mm**
- **For direct mounting on valves, without adjustment**
- **Optional auxiliary switch for additional functions with SQS35.00, SQS35.03, SQS85.00 and SQS85.03**
- **Choice of actuators *with* or *without* spring return function to DIN 32 730**
- **Non-spring return actuators *with* position indication and *with* manual adjustment**
- **Spring return actuators *with* position indication and *without* manual adjustment**

### Application

Used to operate 2-port and 3-port valves with a 5.5 mm stroke. For valve types VVG44..., VVG55..., VVP45..., VMP43..., VMP44..., VMP45..., VXG44..., VXP45..., VVI52...

- Area of application in accordance with IEC 721-3-3 Class 3K5
- Ambient temperatures: -5 ... +50 °C
- Temperature of medium in the connected valve: +2 ... +130 °C
- The use of mounting kit ASK30 enables the following valves with a 4mm or 5.5 mm stroke to be operated: X3i..., VVG45..., VXG45..., VXG46... and VVI51...

### Functions

3-position or proportional control signal

The reversible synchronous motor is driven with a 3-position control signal (SQS35... and SQS85...) or a proportional DC 0...10 V (SQS65, SQS65.5) or DC 2...10 V (SQS65.2) control signal. The corresponding stroke is generated via an anti-locking gear mechanism.

3-position control at terminals Y1 or Y2:

- Voltage at Y1: Valve stem retracts, through-port opens
- Voltage at Y2: Valve stem extends, through-port closes
- No voltage at Y1 or Y2: Valve stem holds current position

## SQS65...

Selecting the flow characteristic

Connector S1 (under the cover, on the printed circuit board) can be repositioned to change the flow characteristic of valves with a 5.5 mm stroke from “equal percentage” to “linear”; in all cases the flow characteristic relates to the through-port of the valve.

- Connecting S1 to pins A and C produces an **equal percentage** flow characteristic (factory setting), primarily for heating applications
- Connecting S1 to pins B and C produces a **linear** flow characteristic, primarily for cooling applications
- For automatic operation, S1 must be connected either to pins A and C, or B and C, depending on the required flow characteristic.

Position of S1

S1 connected to: **A and C**  
(equal-percentage flow characteristic)

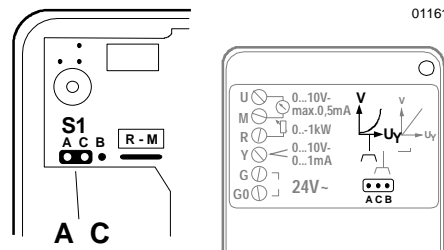

S1 connected to: **C and B**  
(linear flow characteristic)

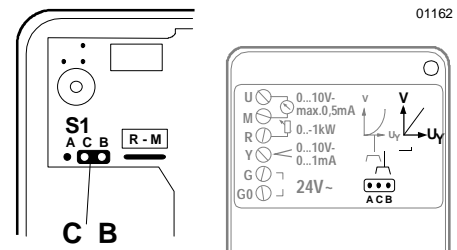

Flow characteristic

Relationship between the DC 0...10 V or DC 2...10 V control signal and the volumetric flow rate

Control signals:

Y = DC 0 ... 10 V or DC 2...10V

R = 0...1000 Ω

Flow characteristic

log = Equal-percentage valve characteristic (factory setting)

lin = Linear valve characteristic

Flow range

$k_{\dot{v}_{100}}$  = Volumetric flow 100%

$k_{\dot{v}_0}$  = Volumetric flow 0 %

Volumetric flow rate

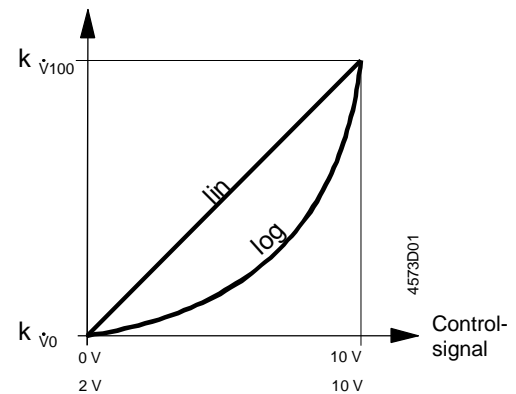

## Types

Type	Operating voltage	Type of control (Control signal)	Run-time [s]	Spring-return function	Spring-return time [s]
<b>SQS35.00</b>	AC 230 V	3-position	150	No	---
<b>SQS35.03</b>			35		
<b>SQS35.50</b>			150	Yes	
<b>SQS35.53</b>			35		
<b>SQS65.5</b>	AC 24 V	DC 0...10 V	35	Yes	8
<b>SQS65</b>				DC 2...10 V	No
<b>SQS65.2</b>					
<b>SQS85.00</b>		3-position	150		
<b>SQS85.03</b>			35		

Accessories

Name	Type	For actuators	Space for
<b>Auxiliary switch</b>	<b>ASC9.6</b>	SQS35.00, SQS35.03 SQS85.00, SQS85.03	1 x ASC9.6

Ordering

When ordering, please specify the quantity, product name, type, and any accessories required.

*Example:* 1 actuator, type **SQS35.00** and 1 auxiliary switch type **ASC9.6**

Delivery

The actuator, valve and accessories are packed separately and not assembled prior to delivery.

## Compatibility

The following 5.5 mm stroke, threaded two-port and three-port valves can be operated with electric actuator types SQS35... , SQS65... and SQS85...

Type	DN [mm]	PN [bar]	Data sheet
<b>Two-port valves</b>			
VVG44...	15 ... 40	16	N4364
VVP45...	10 ... 20	16	N4845
VMP43...(2)	15, 20	16	N4841
VMP44...(2)	15, 20	16	N4844
VVG55...	15 ... 25	25	N4379
VVI52...	15	25	N4377
<b>Three-port valves</b>			
VXG44...	15 ... 40	16	N4464
VXP45...	10 ... 20	16	N4845
VMP43...	15, 20	16	N4841
<b>Three-port valves with bypass "T"</b>			
VMP45...	10 ... 20	16	N4845
VMP43...(4)	15, 20	16	N4841
VMP44...(4)	15, 20	16	N4844

The admissible differential pressure values  $\Delta p_{\max}$  and  $\Delta p_s$  for the complete motorised valve are shown in the relevant valve data sheets.

## Mechanical design

- Electric actuator, no maintenance required
- Reversible synchronous motor
- Anti-locking gear mechanism
- SQS35.50, SQS35.53, SQS65.5 have spring return function to DIN 32730
- Load-dependent switch-off in stroke limit positions
- Selectable flow characteristic: equal percentage or linear for SQS65... actuators in conjunction with valve types VVG44..., VVI52... and VXG44...
- Directly impacting manual adjustment for all non-spring-return actuators: SQS35.00, SQS35.03, SQS65, SQS65.2, SQS85...
- Position indicator on all SQS35..., SQS65..., SQS85... actuators
- Accommodation for auxiliary switch type ASC9.6 on the SQS35.00, SQS35.03, SQS85.00 and SQS85.03 actuators. An auxiliary switch (*not* the ASC9.6) is built in as standard in actuator types SQS35.50 and SQS35.53 actuators.

### Manual adjustment

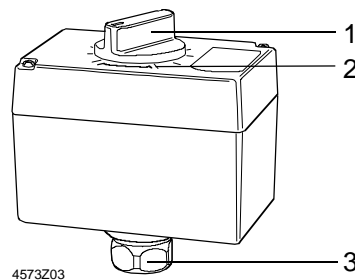

4573Z03

**SQS35.00, SQS35.03**

**SQS65, SQS65.2**

**SQS85...**

- 1 Manual adjustment
- 2 Position indication
- 3 Coupling bolt for valve neck

### Terminal strip, auxiliary switch etc.

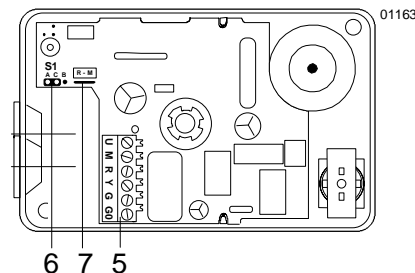

**SQS35..., SQS85...**

- 5 Terminal strip
- 6 Auxiliary switch built-in as standard in SQS35.50 and SQS35.53

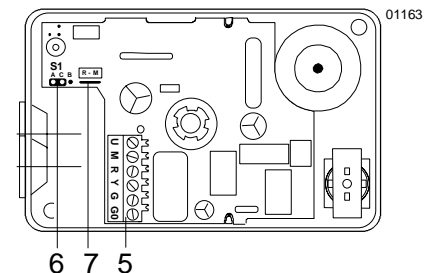

**SQS65...**

- 5 Terminal strip
- 6 «lin» / «log» connection
- 7 Bridge R – M

## Accessories

### ASC9.6 auxiliary switch

Suitable for actuator types SQS35.00, SQS35.03, SQS85.00 and SQS85.03  
Switching point adjustable from 0...100% stroke  
See "Technical data" for further information on accessories

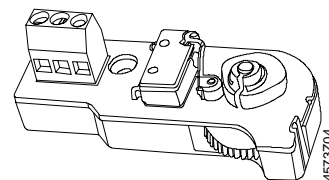

## Disposal

The actuator must be dismantled and separated into its various constituent materials before disposal.

## Engineering

The actuators must be electrically connected in accordance with local regulations and with the connection diagrams.



### Caution:

**Regulations and requirements to ensure the safety of people and property must be observed at all times.**

SQS65...

**With the SQS65... actuators, the connector used to select the flow characteristic must be set to "lin" for valve types VVG55..., VMP..., VVP... and VXP...**

The admissible temperatures (see "Application" and "Technical data") must be observed. If an auxiliary switch is required, its switching point must be indicated on the plant schematic.

## Mounting

### Orientation

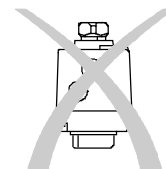
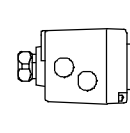
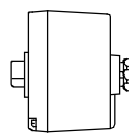
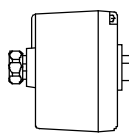
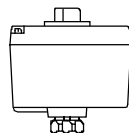

*Permissible*

*Not permissible*

Instructions for fitting the actuator to the valve are shown on the back of the actuator housing. The instructions for accessories are enclosed with the accessories themselves.

## Commissioning

When commissioning the system, check the wiring and functions. In addition, set the auxiliary switch or check the settings.

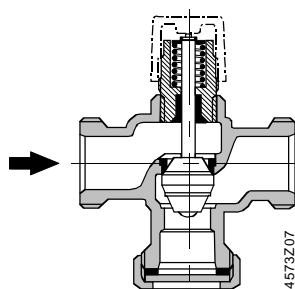

Stroke «0» = Valve closed

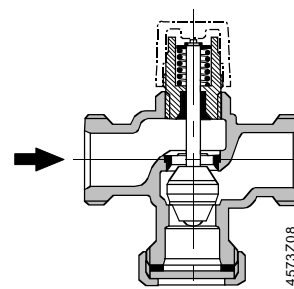

Stroke «1» = Valve open

**Manual adjuster** Turning the manual adjuster in an anti-clockwise direction causes Landis & Staefa valves with a 5.5 mm stroke to close (= 0% stroke).

**SQS35... / SQS85...** Used in conjunction with valve types VVG44..., VVI52... or VXG44..., these actuators generate a linear flow characteristic.

**SQS65...** In conjunction with valve types VVG44..., VVI52... or VXG44... these actuators generate an equal-percentage flow characteristic (factory-setting) via the integrated electronic assembly. The flow characteristic can be changed to "linear" by repositioning the connector.

---

## Warranty

The technical data ( $\Delta p_{max}$ ,  $\Delta p_s$ , leakage rates, noise levels, service life etc.) given for the applications described applies only to the Landis & Staefa valves listed in this data sheet under "Compatibility".

**The use of type SQS... actuators in conjunction with third-party valves invalidates all claims under the Landis & Staefa warranty.**

---

## Maintenance

When servicing the valve: switch OFF the pump and power supply, close the main shut-off valve in the pipework, release pressure in the pipes and allow them to cool down completely. If necessary, disconnect electrical connections from terminals.

The actuator must be correctly fitted to the valve before re-commissioning.

---

## Technical data

### Power supply

Operating voltage	
SQS35...	AC 230 V $\pm$ 15 % , 50 / 60 Hz
SQS65...	AC 24 V $\pm$ 20 % , 50 / 60 Hz
SQS85...	AC 24 V $\pm$ 20 % , 50 / 60 Hz
Power consumption	
SQS35.00	2.5 VA
SQS35.03	3.5 VA
SQS35.50	5 VA
SQS35.53	6 VA
SQS65, SQS65.2	4.5 VA
SQS65.5	7 VA
SQS85.00	2 VA
SQS85.03	2 VA
Switching capacity of limit switches	Terminals 11 or 12
SQS35..., SQS85...	AC 250 V, 6 A resistive / 2.5 A inductive

### Operating data

Type of control (control signal)	
SQS85...	3-position
SQS65, SQS65.5	DC 0...10 V (proportional)
SQS65.2	DC 2...10 V (proportional)
Run-time	Opening or closing
SQS35.00, SQS35.50, SQS85.00	150 s at 50 Hz
SQS35.03, SQS35.53, SQS85.03	35 s at 50 Hz
SQS65, SQS65.2, SQS65.5	35 s at 50 Hz
Spring return feature	
SQS35.50, SQS35.53, SQS65.5	Closing time 8 s
Positioning force	400 N
Stroke	5.5 mm

### Signal inputs

Terminal Y (SQS65, SQS65.5)	DC 0 ... 10 V, max. 0.1 mA
Terminal Y (SQS65.2)	DC 2 ... 10 V, max. 0.1 mA
Terminal R (SQS65, SQS65.5, SQS65.2)	Resistance 0 ... 1000 $\Omega$

### Signal outputs

Terminal U (SQS65, SQS65.5, SQS65.2)	DC 0 ... 10 V, max. 0.5 mA
--------------------------------------	----------------------------

### Housing protection standard

Housing protection standard	IP54 to EN 60529
Cable glands	Pg11 (2 x)

### Ambient conditions

Temperature of medium in the connected valve	+2 ... +130 °C
--	----------------

Operation	To IEC 721-3-3
Environmental conditions	Class 3K5
Temperature	-5 ... +50 °C
Humidity	5... 95 %rh
Transport	To IEC 721-2-3
Environmental conditions	Class 2K3
Temperature	-25 ... +70 °C
Humidity	< 95 %rh
Storage	To IEC 721-1-3
Environmental conditions	Class 1K3
Temperature	-5 ... +50 °C
Humidity	5 ... 95 %rh

**Industry standards**

Meets the requirements for <b>CE</b> marking:	
EMC Directive	89/336/EEC
Low Voltage Directive	73/23/EEC

**Dimensions / Weight**

Dimensions	See "Dimensions"
Weight	
SQS35.00, SQS35.03, SQS65, SQS65.2, SQS85.00, SQS85.03	
Excluding packaging	0.5 kg
With packaging	0.6 kg
SQS35.50, SQS35.53, SQS65.5	
Excluding packaging	0.6 kg
With packaging	0.7 kg

**Materials**

Actuator housing	Plastics
Housing cover and manual adjuster	Plastics
Gear train and stem with coupling	Plastics

**Accessories**

<b>ASC9.6</b> auxiliary switch for SQS35... and SQS85...	
Switching capacity	AC 250 V, 10 A resistive / 3 A inductive

**Connection diagram  
SQS35...**

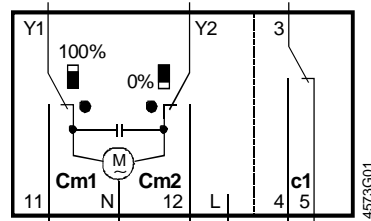

**SQS35.00, SQS35.03**

AC 230 V, 3-position, non-spring return

- Cm1 Limit switch 100 % stroke
- Cm2 Limit switch 0 % stroke
- c1 ASC9.6 auxiliary switch can be fitted
- L Volt-free loop terminal for live wire

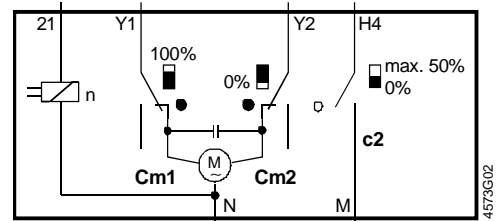

**SQS35.50, SQS35.53**

AC 230 V, 3-position, with spring return

- c2 Built-in auxiliary switch with fixed preset minimum flow limit control. (Factory-fitted, not accessory like ASC9.6)

**SQS85...**

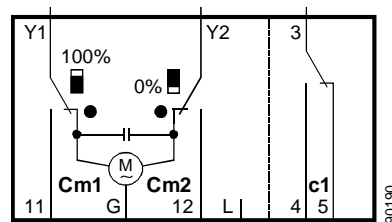

**SQS85.00, SQS85.03**

AC 24 V, 3-position, non-spring return

- Cm1 Limit switch 100 % stroke
- Cm2 Limit switch 0 % stroke
- c1 ASC9.6 auxiliary switch can be fitted
- L Volt-free loop terminal for live wire

## Connection diagrams

Connection terminals  
SQS65....

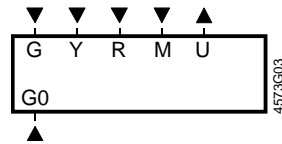

G, G0 Operating voltage AC 24 V  
G System potential (SP) corresponds to LS on SQS65.2  
G0 System neutral (SN) corresponds to NS on SQS65.2

Signal inputs

Y SQS65, SQS65.5 DC 0...10 V  
SQS65.2 DC 2...10 V

RSQS65, SQS65.2, SQS65.50 ...1000 ohms

M Measuring neutral

USignal output

SQS65, SQS65.2, SQS65.5 DC 0...10 V

All connection options are illustrated in the connection diagrams. How many and which of these are used, depends on the system.

Note

If a device is connected to terminal R, the factory-fitted bridge across R – M on the printed circuit board must be cut through.

**SQS65, SQS65.5**  
(AC 24 V, DC 0 ...10 V)

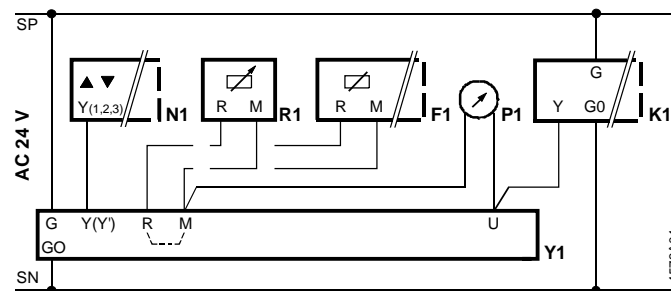

**SQS65.2**  
(AC 24 V, DC 2 ...10 V)

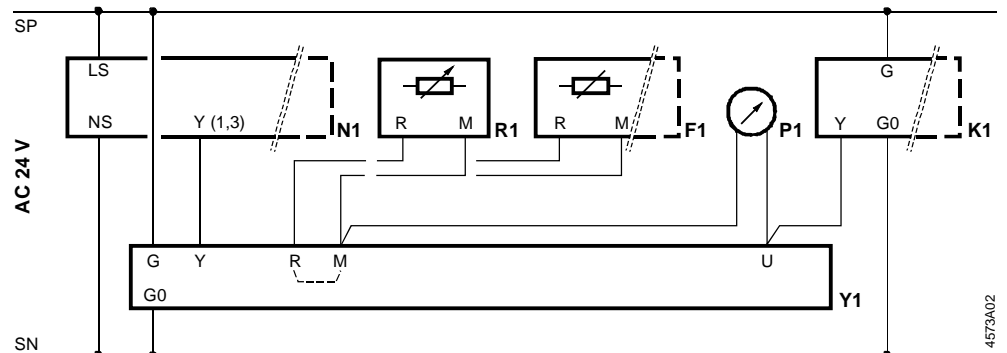

### Equipment

F1 Frost detector  
K1 On/off switch  
N1 CLASSIC controller  
P1 Position indicator  
R1 Position transmitter

K1 On/off switch  
N1 CLASSIC controller  
P1 Position indicator  
R1 Position transmitter  
Y1 Actuator

## Dimensions

All dimensions in mm

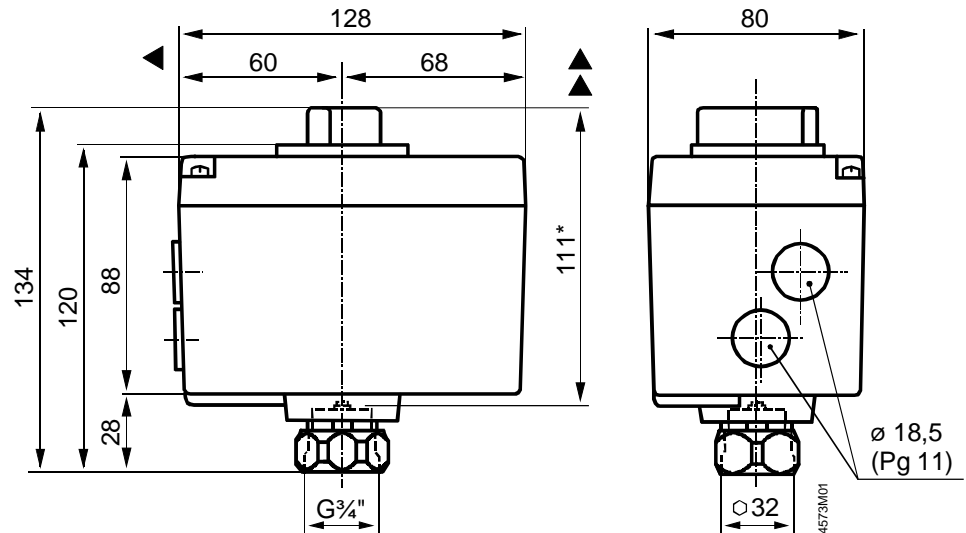

- \* Height of actuator after fitting on valve
- ◄ > 100 mm Minimum clearance from wall or ceiling
- ▲ > 200 mm for mounting, connection, operation, service etc.